



**FW-IOB-T-120/208VAC**

**Input/Output/Bypass Assembly**

Installation Instructions



The OutBack Power Systems FW-IOB-T-120/208VAC allows manual switching between the FX Series Inverter/Charger and a second AC source, facilitating maintenance and power continuity.

### **About OutBack Power Systems**

OutBack Power Systems is a leader in advanced energy conversion technology. Our products include true sine wave inverter/chargers, a maximum power point charge controller, system communication components, as well as breaker panels, breakers, accessories, and assembled systems.

### **Notice of Copyright**

FW-IOB-T-120/208VAC Installation Instructions  
Copyright © 2006 All rights reserved.

### **Disclaimer**

UNLESS SPECIFICALLY AGREED TO IN WRITING, OUTBACK POWER SYSTEMS:

- (a) MAKES NO WARRANTY AS TO THE ACCURACY, SUFFICIENCY OR SUITABILITY OF ANY TECHNICAL OR OTHER INFORMATION PROVIDED IN ITS MANUALS OR OTHER DOCUMENTATION.
- (b) ASSUMES NO RESPONSIBILITY OR LIABILITY FOR LOSS OR DAMAGE, WHETHER DIRECT, INDIRECT, CONSEQUENTIAL OR INCIDENTAL, WHICH MIGHT ARISE OUT OF THE USE OF SUCH INFORMATION. THE USE OF ANY SUCH INFORMATION WILL BE ENTIRELY AT THE USER'S RISK.

### **Date and Revision**

November 1, 2006                      1.0

### **Contact Information**

OutBack Power Systems  
19009 62nd Ave. NE  
Arlington, WA 98223  
Phone (360) 435-6030  
Fax (360) 435-6019  
[www.outbackpower.com](http://www.outbackpower.com)

## Requirements and Warnings

The OutBack FW-IOB-T-120/208VAC is intended as a system component and is included in a listing by ETL as indoor enclosures to UL standard UL 508A Industrial Control Panels.

This enclosure is intended for battery circuits configured for 12 to 48 volts nominal.

Grounding Instructions – Each enclosure should be connected to a grounded, permanent wiring system. For most installations, the negative battery conductor should be bonded to the grounding system at one (and only one) point in the DC system. All installations must comply with all national and local codes and ordinances. System grounding as required by the National Electric Code, ANSI /NFPA 70-1996, is the responsibility of the system installer.

The equipment ground is marked with this symbol: 

# FW-IOB-T-120/208VAC Parts List

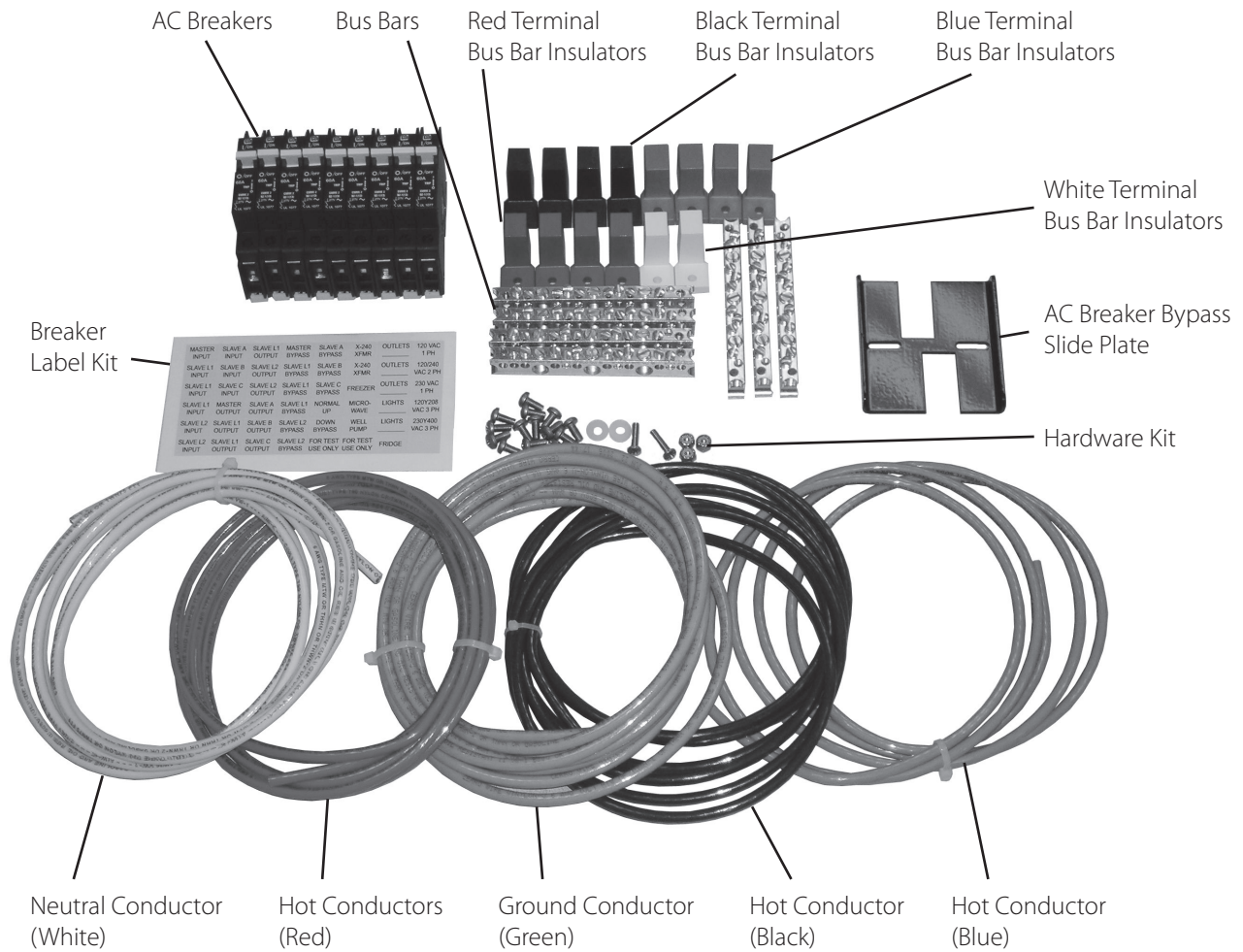

Figure 1: FW-IOB-T-120/208VAC

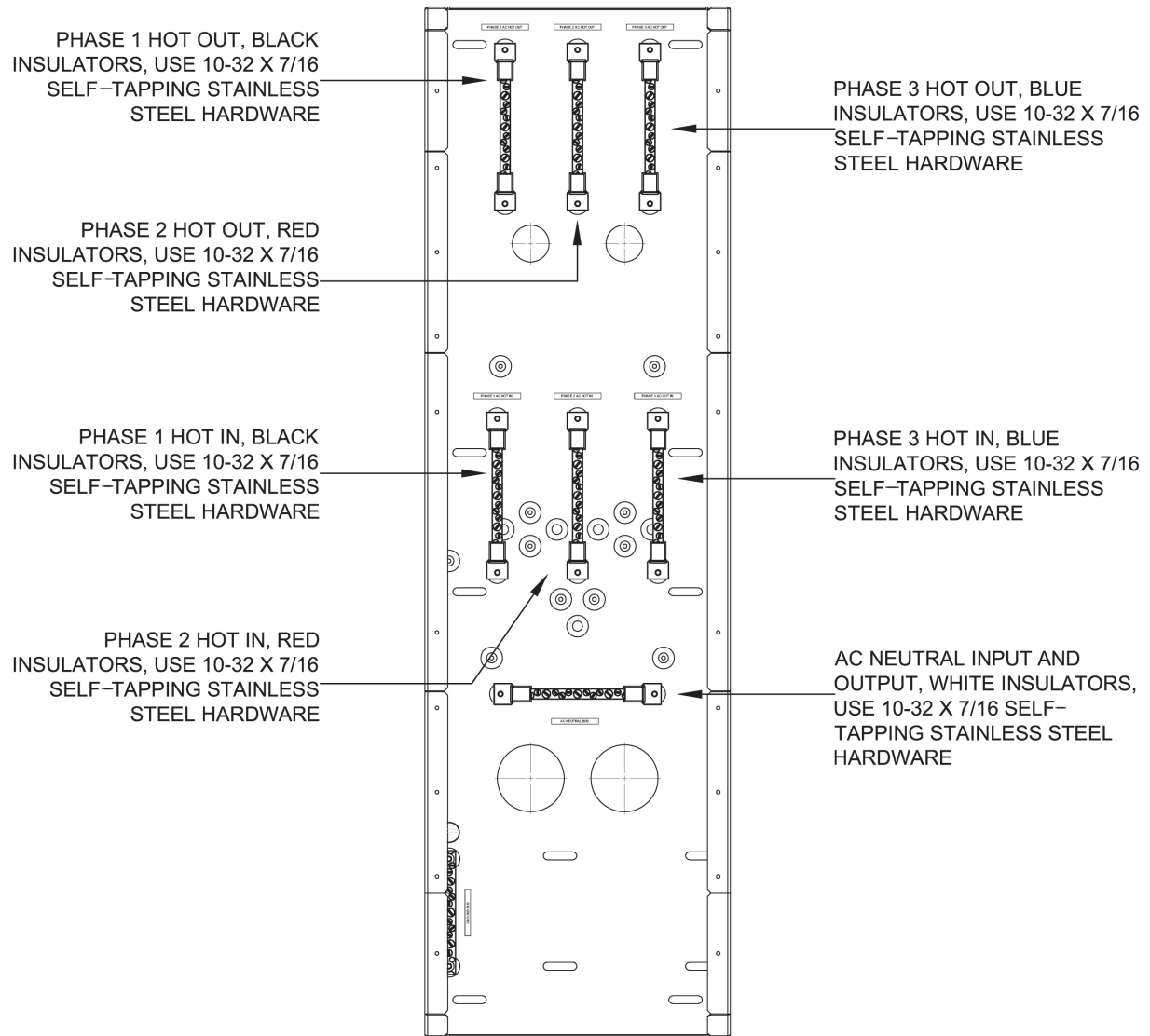

Figure 2: Placement of Bus Bars

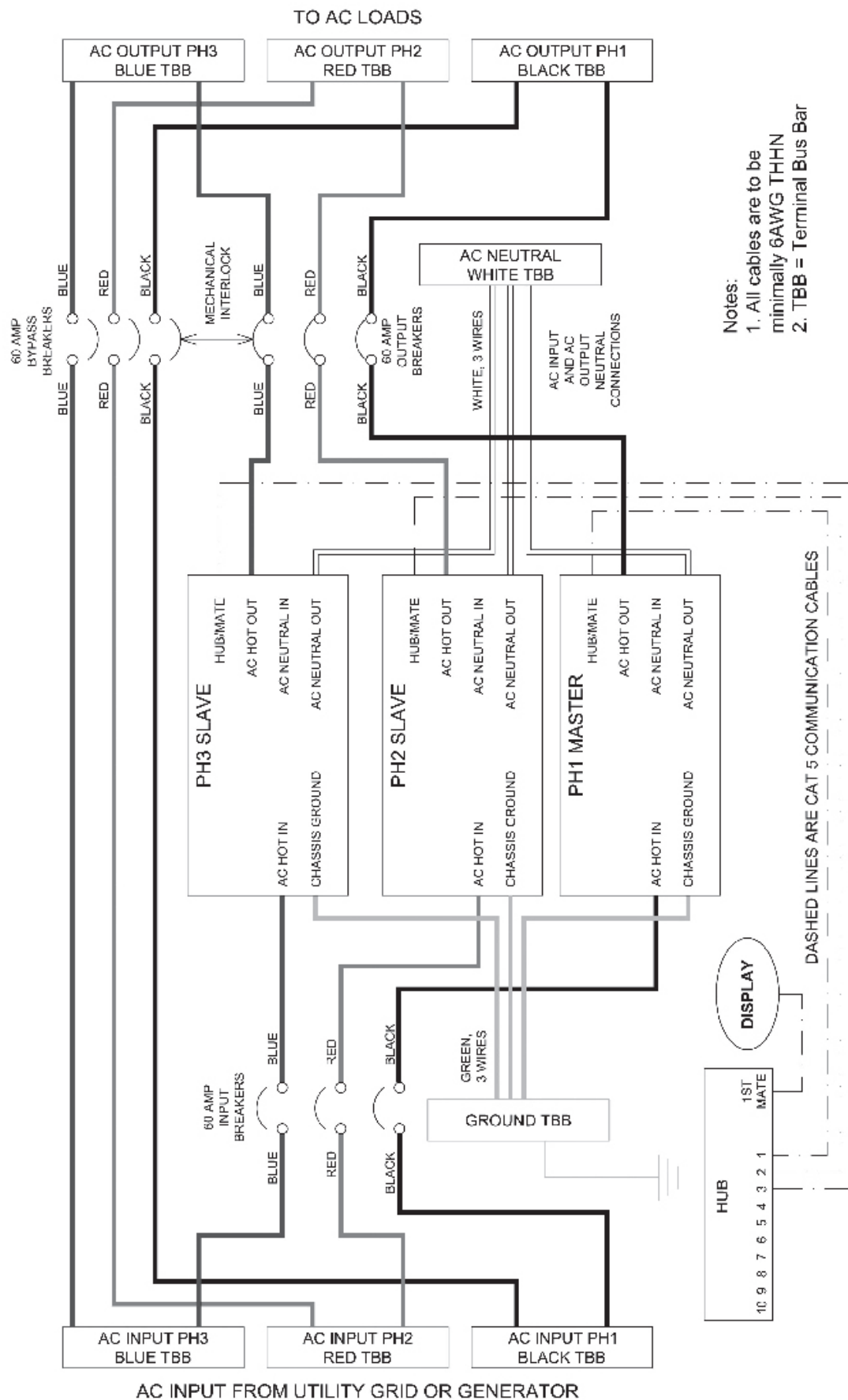
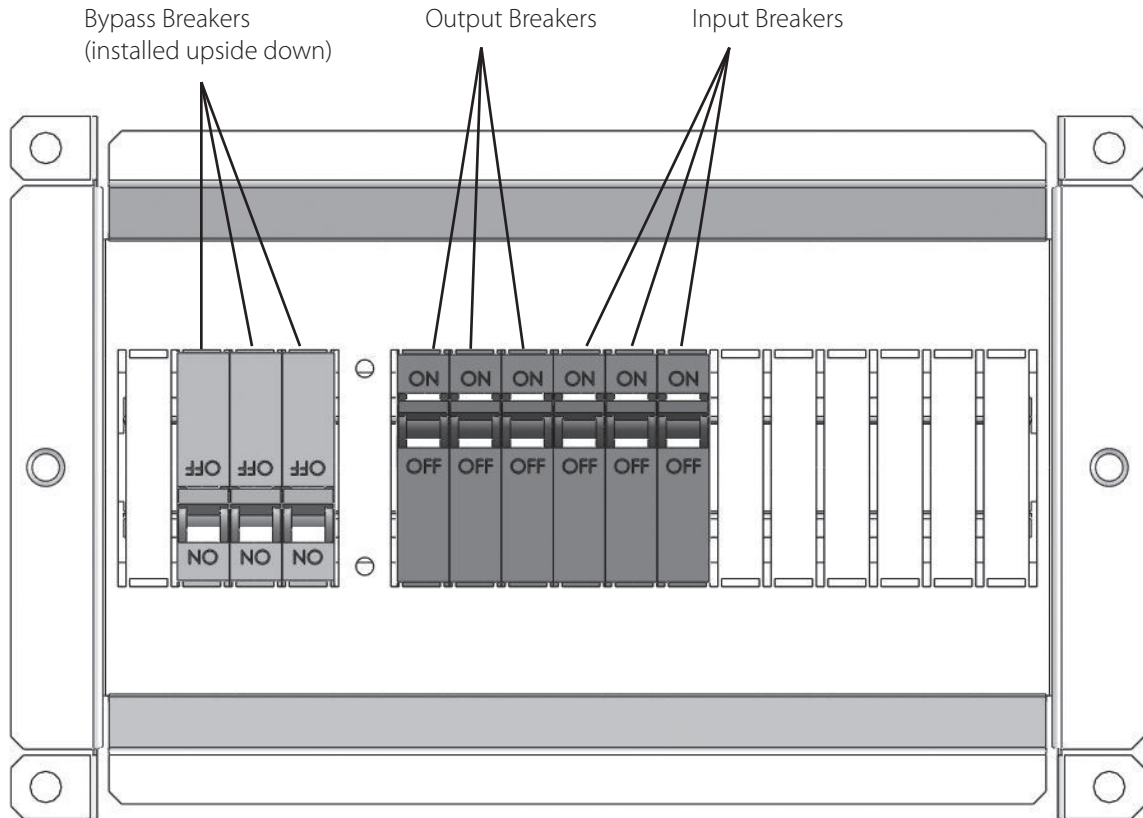

Figure 3: Sample Wiring Diagram

## Installing the FW-IOB-T-120/208VAC

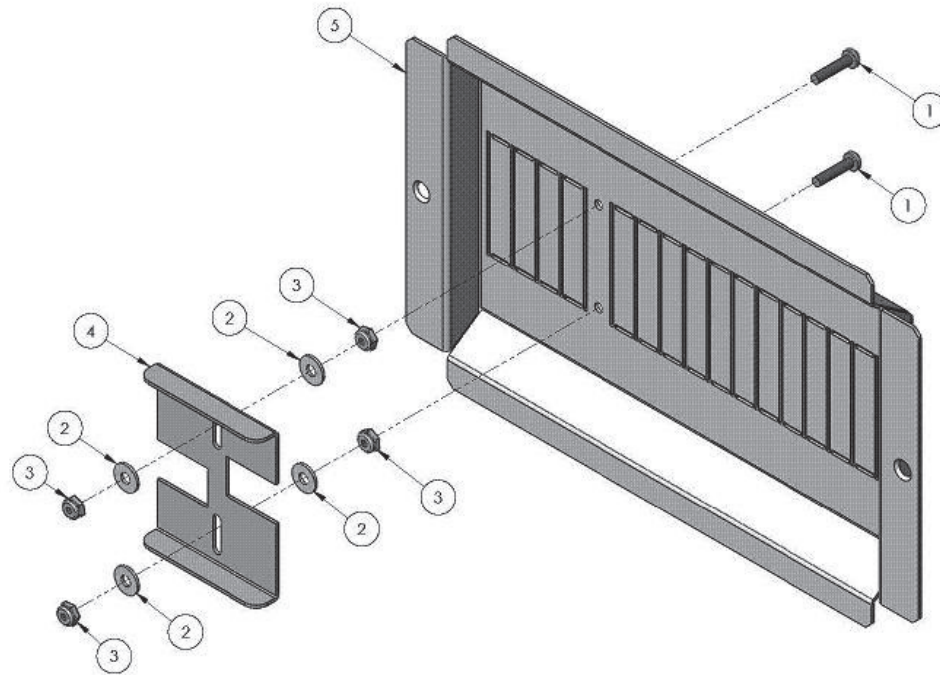

**Figure 4:** AC Breaker Installation for FW-IOB-T-120/208VAC

To install the FW-IOB-T-120/208VAC:

- Remove the appropriate quantity of breaker knockouts from the breaker bracket.
- Pull the yellow tabs out from each breaker.
- Install the breakers on the din rail to approximately match the openings in the breaker bracket.
- Hold the breaker bracket loosely against the breakers on the din rail; move the breakers as needed so they line up with the openings in the breaker bracket.
- With the breakers positioned properly, lock the yellow tabs to secure the breakers to the din rail.
- Install the AC Breaker Bypass Slide Plate (see Figure 5).

## Installing the AC Breaker Bypass Slide Plate



*Figure 5:* AC Breaker Bypass Slide Plate Installation

### Parts:

1. 8-32 X .75 Machine Screw (2)
2. Nylon Washer (4)
3. 8-32 Nylock Nut (4)
4. AC Breaker Bypass Slide Plate (1)
5. FLEXware AC Breaker Bracket (1)

### To Assemble:

1. Remove necessary circuit breaker knockouts (per IOB kit).
2. Install AC Breaker Bypass Slide Plate and fasteners as shown in Figure 5.
3. Do not over tighten the Nylock nuts. Overtightening can cause the AC Breaker Bypass Slide Plate to bind.

---

19009 62nd Avenue NE  
Arlington, WA USA  
(+1) 360-435-6030

European Sales Office  
Barcelona, España  
(+34) 600-843-845

[www.outbackpower.com](http://www.outbackpower.com)